

CHERRY SST™

BLIND RIVET SYSTEM

U.S. PATENT NO.

4,012,984

5,052,870

5,056,973



TEXTRON Aerospace Fasteners

THE SST™ BLIND RIVET SYSTEM

INDEX

SST™ Blind Rivet Features and Benefits	1
SST™ Blind Rivet Installation	2
Part Numbering System/Head Styles	3
Physical Properties	4
SST™ Blind Rivet Standards Pages	
Oversize Shank Diameter	
Universal Head	5
100° Flush Head	6
Nominal Shank Diameter	
Universal Head	7
100° Flush Head	8
100° Flush Head (NAS1097).	9
SST™ Blind Rivet Tooling	
Tool Selection	10
Installation Tooling	11-12

ATTENTION
Blind rivets are not always a suitable substitute for solid rivets. Maintenance personnel are reminded that AC 43.13-1A chapter 2, section 3 stipulates: "Do not substitute hollow rivets for solid rivets in load carrying members without specific approval of the application by a representative of the Federal Aviation Administration. Blind rivets may be used in blind locations in accordance with the conditions listed in Chapter 5, provided the edge distances and spacings are not less than the minimum listed in paragraph 99d."

Cherry® is a Registered Trademark of Cherry Division of Textron, Inc.

CR® is a Registered Trademark of Cherry Division of Textron, Inc.

SST™ is a Trademark of Cherry Division of Textron, Inc.



AEROSPACE FASTENING SYSTEMS

Cherry, Division of Textron, Inc.
1224 East Warner Ave., Box 2157
Santa Ana, CA 92707
(714) 545-5511
FAX (714) 850-6095

THE SST™ BLIND RIVET SYSTEM

SST™ "SUPERIOR SHEET TAKE-UP" BLIND RIVET SYSTEM

The Cherry **SST™** Blind Rivet System was designed to solve many of the blind fastening problems associated with aircraft assemblies requiring superior sheet take-up. Installation of the **SST** Blind Rivet System ensures consistent and permanent fastening of difficult assemblies with inherent gapping or slightly misaligned holes. The **SST** Blind Rivet System can be installed with standard CherryMax® tooling with no adjustments needed. Eliminate sheet gaps in your toughest assemblies...use the **SST** Blind Fastening System for **Superior Sheet Take-Up**.

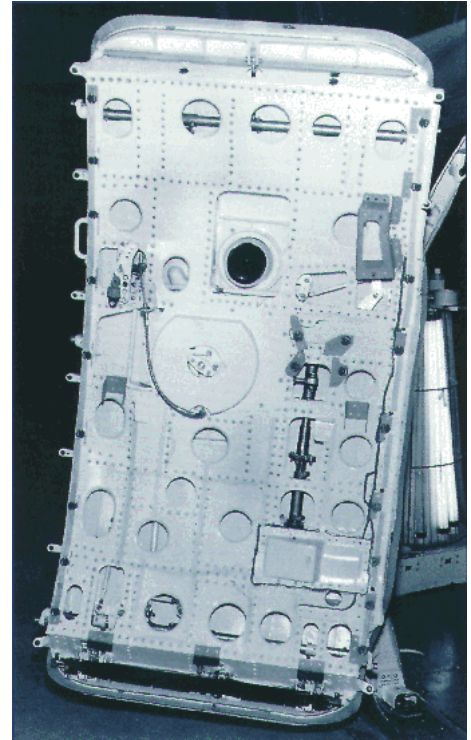

*Typical aircraft door assembly utilizing Cherry's advanced **SST** Blind Rivet System.*

PRODUCT FEATURES

- **Superior Sheet Take-Up**
- Inspectable stem/collar relationship
- Cadmium free, non-magnetic stem
- One tool concept/no adjustments
- Flat bearing surface on the periphery of protruding head rivets
- New driving anvil on each rivet

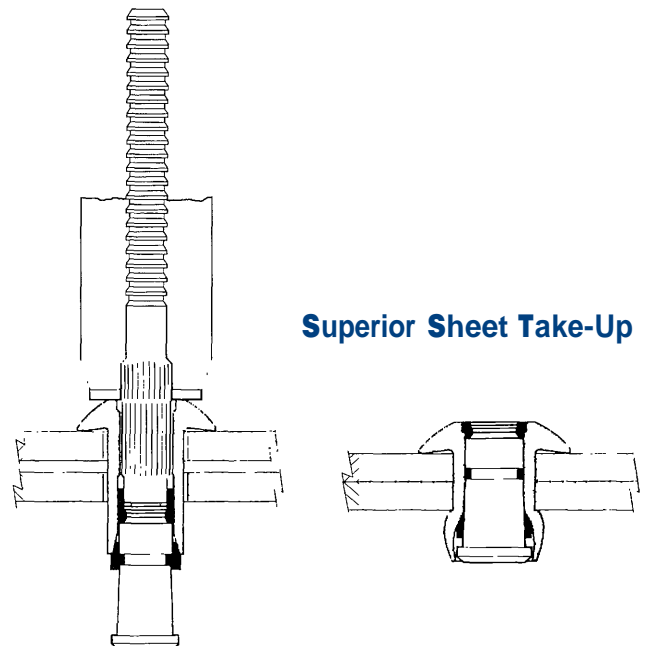

THE SST™ BLIND RIVET SYSTEM

INSTALLATION

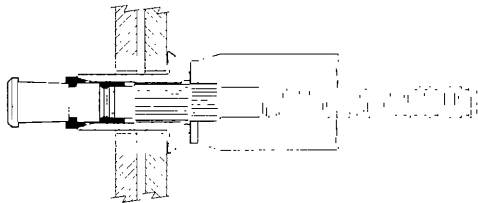

1

The Cherry **SST™** Blind Rivet is inserted into the prepared hole. The pulling head (Installation Tool) is slipped over the stem. Applying firm pressure, which seats the rivet head, the installation tool is actuated.

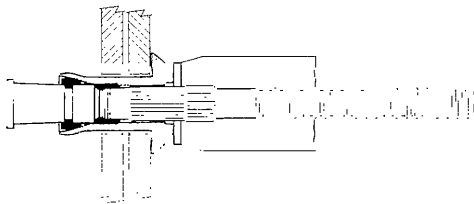

2

The pulling head holds the rivet in place as it begins to pull the rivet stem through the rivet sleeve. The rivet starts to compress the two sheets together.

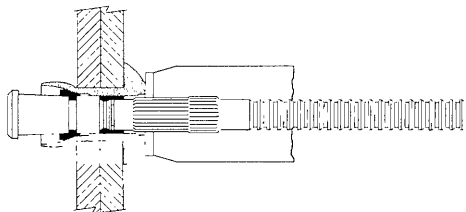

3

Continued pulling action firmly clamps the sheets together. The rivet head is securely seated and the rivet sleeve expands to fill the hole.

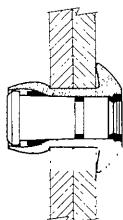

4

Pressure of the driving anvil cold forms the locking collar into the recess head of the fastener. Continued pulling fractures the stem, providing a flush burr-free installation.

THE SST™ BLIND RIVET SYSTEM

NUMBERING SYSTEM

Part Number Example:

CR6253 -6 -05

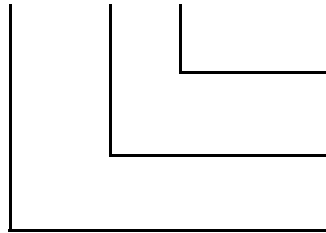

*Grip Dash Number
(Maximum Grip in 1/16 Increments)*

*Diameter Dash Number
(Diameter in 1/32 Increments)*

*Basic Part Number
(Materials, Head Style, and Diameter Series)*

HEAD STYLES

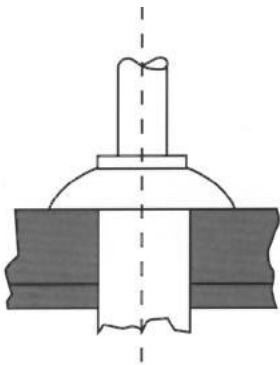

UNIVERSAL

For protruding head applications. Available in both nominal & oversize.

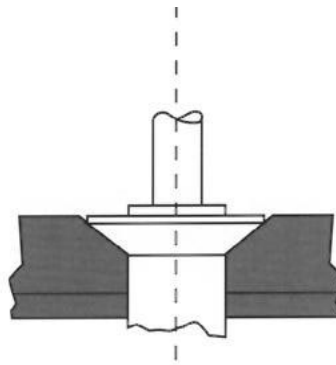

100° FLUSH

For countersink applications. Available in both nominal and oversize.

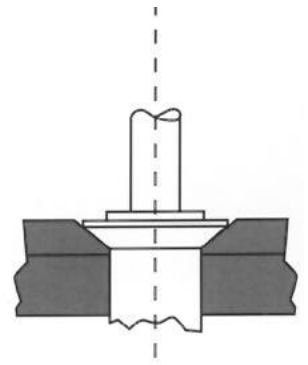

**100° FLUSH
(NAS1097)**

For thin top sheet, machine countersunk applications. Available in nominal only.

SST™ PHYSICAL PROPERTIES

MECHANICAL PROPERTIES

MATERIAL		ULTIMATE SHEAR STRENGTH	MAXIMUM TEMPERATURE
SLEEVE	STEM		
5056 Aluminum	A-286 CRES	50,000 PSI	250°F

MINIMUM RIVET SHEAR & TENSILE STRENGTH (LBS.) IN STEEL COUPONS

RIVET DIAMETER	SINGLE SHEAR			TENSILE		
	SHEET THICKNESS	NOMINAL	O/S	NOMINAL		O/S
		CR6222 CR6223 CR6224	CR6252 CR6253	CR6222 CR6223	CR6224	CR6252 CR6253
1/8" (-4)	2 x .156"	664	814	285	250	345
5/32" (-5)	2 x .187"	1030	1245	445	390	530
3/16" (-6)	2 x .219"	1480	1685	635	560	710

ATTENTION

Blind rivets are not always a suitable substitute for solid rivets. Maintenance personnel are reminded that AC 43.13-1A chapter 2, section 3 stipulates: "Do not substitute hollow rivets for solid rivets in load carrying members without specific approval of the application by a representative of the Federal Aviation Administration. Blind rivets may be used in blind locations in accordance with the conditions listed in Chapter 5, provided the edge distances and spacings are not less than the minimum listed in paragraph 99d."

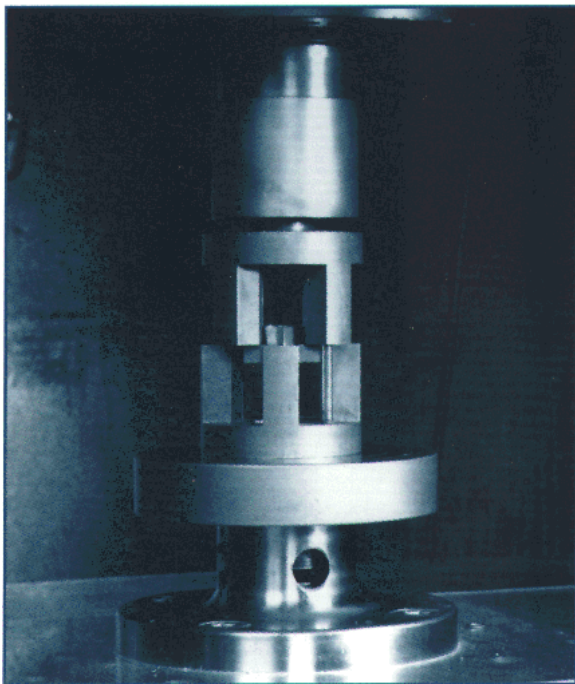

Tensile Testing Fixture

INSTALLED WEIGHT (LBS./1,000)

STYLE	GRIP LENGTH	-4 DIA	-5 DIA	-6 DIA
CR6252	-02	.83	1.42	2.14
	-03	1.00	1.71	2.49
	-04	1.18	1.92	2.84
	-05	1.35	2.20	3.25
	-06	1.53	2.48	3.62
	-07	1.71	2.76	3.97
	-08	1.89	3.05	4.34
	-09	2.07	3.33	4.72
	-10	-	-	5.10
	CR6253	-01	.88	1.57
-02		1.07	1.85	2.89
-03		1.25	2.13	3.22
-04		1.43	2.40	3.59
-05		1.62	2.68	3.96
-06		1.80	2.96	4.31
-07		1.98	3.24	4.78
-08		2.16	3.52	5.18
-09		2.35	3.80	5.56
-10		-	-	5.93
CR6222	-02	.71	1.21	1.80
	-03	.84	1.42	2.13
	-04	.97	1.64	2.45
	-05	1.09	1.86	2.77
	-06	1.22	2.07	3.09
	-07	1.35	2.28	3.41
	-08	1.47	2.50	3.73
	-09	1.60	2.71	4.05
	-10	1.73	2.93	4.37
	CR6223	-01	.85	1.45
-02		.99	1.68	2.50
-03		1.12	1.90	2.84
-04		1.26	2.13	3.18
-05		1.39	2.35	3.51
-06		1.52	2.58	3.85
-07		1.66	2.81	4.19
-08		1.79	3.04	4.53
-09		1.93	3.26	4.87
-10		2.06	3.49	5.21
CR6224	-02	.67	1.14	1.71
	-03	.80	1.35	2.02
	-04	.92	1.56	2.32
	-05	1.04	1.76	2.63
	-06	1.16	1.96	2.93
	-07	1.28	2.17	3.23
	-08	1.40	2.37	3.54
	-09	1.52	2.57	3.84
	-10	1.64	2.78	4.14

CR6253 SST™ RIVET - UNIVERSAL HEAD/OVERSIZE DIAMETER

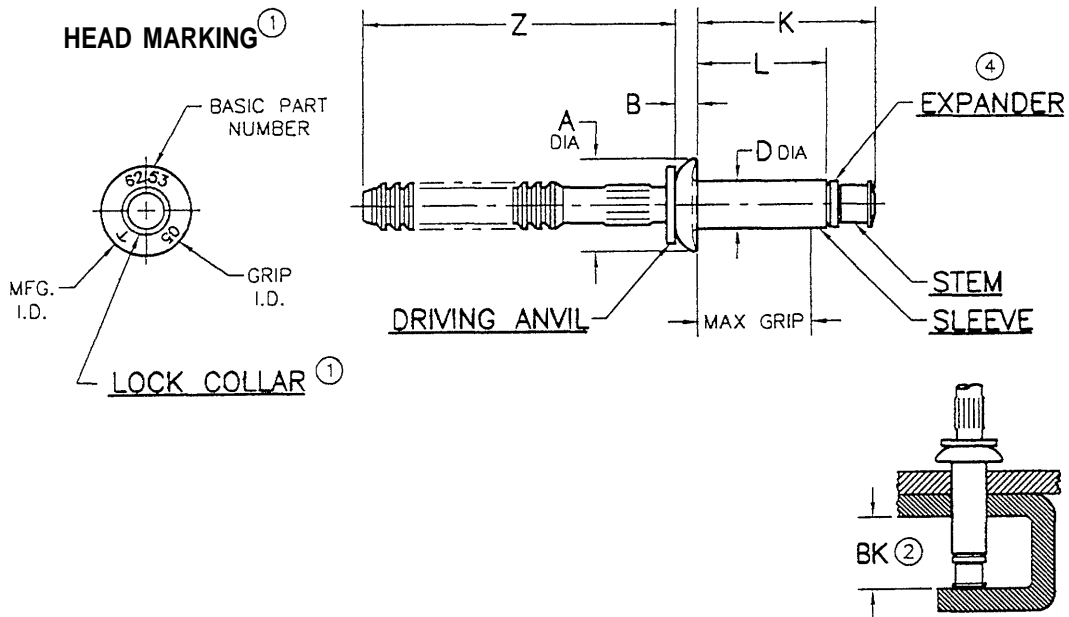

DIA. DASH NO.	A ±.010	B ±.005	D ±.002	Z REF.	BK ② MIN	RECOMMENDED HOLE LIMITS
-4	.250	.059	.141	.87	.390	.143/.146
-5	.312	.072	.174	.94	.395	.176/.180
-6	.375	.085	.202	.94	.410	.205/.209

MATERIAL ③				FINISH			
SLEEVE	STEM	LOCK COLLAR	EXPANDER	SLEEVE	STEM	LOCK COLLAR	EXPANDER
5056 ALUM. QQ-A-430	A-286 CRES AMS 5731	A-286 CRES AMS 5731	A-286 CRES AMS 5731 or 300 SERIES CRES PER ASTM-A-493	CHEM. FILM MIL-C-5541 plain color	PASSIVATE QQ-P-35	NONE	NONE

GRIP DASH NO.	GRIP LIMITS		-4 DIA		-5 DIA		-6 DIA	
	MIN	MAX	L ±.015	K REF	L ±.015	K REF	L ±.015	K REF
-01	⑤	.062	.153	.37	.160	.40	.175	.45
-02	.063	.125	.216	.49	.223	.52	.238	.56
-03	.126	.187	.277	.54	.285	.56	.300	.60
-04	.188	.250	.341	.60	.348	.63	.363	.66
-05	.251	.312	.403	.66	.410	.69	.425	.72
-06	.313	.375	.466	.72	.473	.75	.488	.79
-07	.376	.437	.528	.79	.535	.81	.550	.85
-08	.438	.500	.591	.85	.598	.88	.613	.91
-09	.501	.562	.653	.91	.660	.94	.675	.97
-10	.563	.625	-	-	.723	-	.738	1.04

NOTES:

- ① Head markings and lock collar visible after installation. Head markings depressed .010 max.
- ② Minimum blind side clearance for satisfactory installation.
- ③ Material designation refers to chemical composition only.
- ④ Expander may be 1 or 2 piece design.
- ⑤ Minimum grip for -4 dia. is .025, for -5 dia. is .031, and for -6 dia. is .037.

CR6252 SST™ RIVET - FLUSH HEAD/OVERSIZE DIAMETER

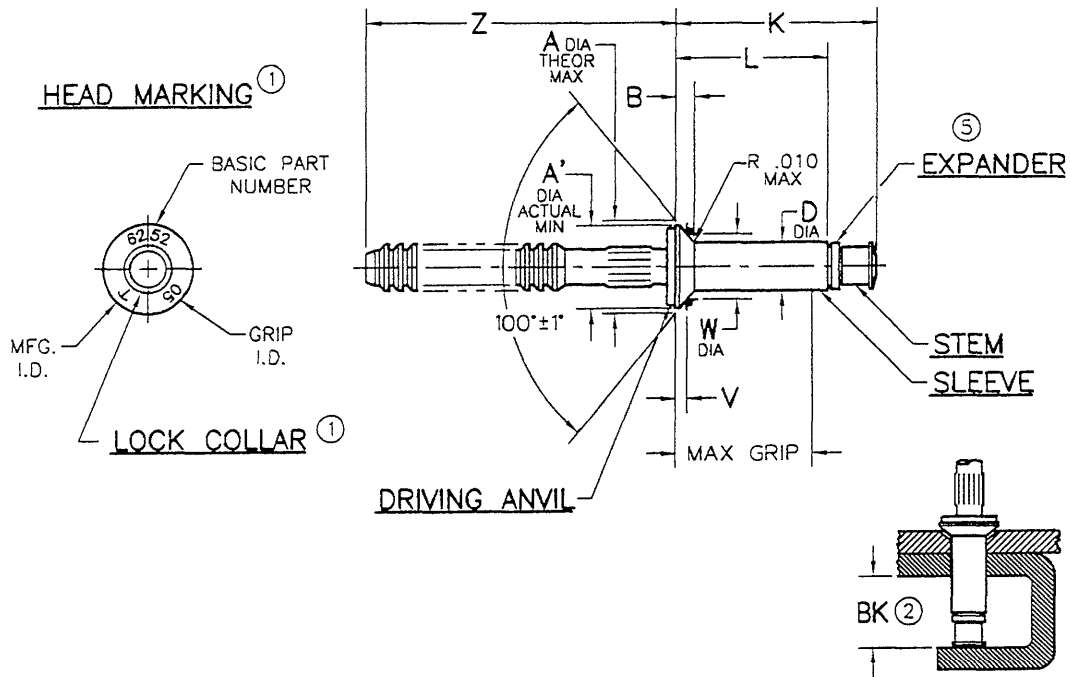

DIA. DASH NO.	A ^④ THEOR MAX	A' ACTUAL MIN	B ^④ MAX	D ±.002	Z REF	BK ^② MIN	V ±.0015	W +.0001	RECOMMENDED HOLE LIMITS
-4	.229	.207	.038	.141	.87	.390	.0170	.1840	.143/.146
-5	.290	.268	.050	.174	.94	.395	.0215	.2340	.176/.180
-6	.351	.335	.067	.202	.94	.410	.0285	.2840	.205/.209

MATERIAL ^③				FINISH			
SLEEVE	STEM	LOCK COLLAR	EXPANDER	SLEEVE	STEM	LOCK COLLAR	EXPANDER
5056 ALUM. QQ-A-430	A-286 CRES AMS 5731	A-286 CRES AMS 5731	A-286 CRES AMS 5731 300 SERIES CRES PER ASTM-A-493	CHEM. FILM MIL-C-5541 plain color	PASSIVATE QQ-P-35	NONE	NONE

GRIP DASH NO.	GRIP LIMITS		-4 DIA		-5 DIA		-6 DIA	
	MIN	MAX	L ±.015	K REF	L ±.015	K REF	L ±.015	K REF
-02	⑥	.125	.216	.43	.223	.46	.238	.48
-03	.126	.187	.277	.55	.285	.58	.300	.60
-04	.188	.250	.341	.59	.348	.62	.363	.65
-05	.251	.312	.403	.65	.410	.68	.425	.71
-06	.313	.375	.466	.71	.473	.74	.488	.78
-07	.376	.437	.528	.78	.535	.80	.550	.84
-08	.438	.500	.591	.84	.598	.87	.613	.90
-09	.501	.562	.653	.90	.660	.93	.675	.96
-10	.563	.625	-	-	-	-	.738	1.03

NOTES:

- ① Head markings and lock collar visible after installation. Head markings depressed .010 max.
- ② Minimum blind side clearance for satisfactory installation.
- ③ Material designation refers to chemical composition only.
- ④ Theoretical diameter "A" max. and head height "B" max. are for engineering reference only.
- ⑤ Expander may be 1 or 2 piece design.
- ⑥ Minimum grip for -4 diameter is .063, -5 diameter is .063, and -6 diameter is .073.

CR6223 SST™ RIVET - UNIVERSAL HEAD/NOMINAL DIAMETER

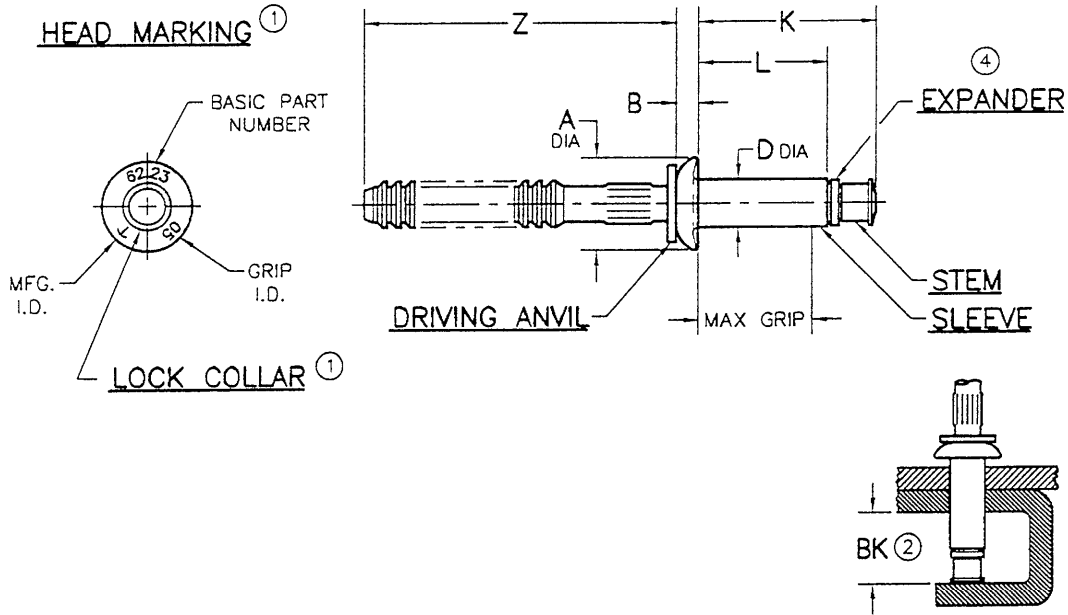

DIA. DASH NO.	A ±.010	B ±.005	D ±.002	Z REF.	BK ② MIN	RECOMMENDED HOLE LIMITS
-4	.250	.059	.127	.87	.355	.132/.129
-5	.312	.072	.158	.94	.370	.164/.160
-6	.375	.085	.190	.94	.415	.196/.192

MATERIAL ③				FINISH			
SLEEVE	STEM	LOCK COLLAR	EXPANDER	SLEEVE	STEM	LOCK COLLAR	EXPANDER
5056 ALUM. QQ-A-430	A-286 CRES AMS 5731	A-286 CRES AMS 5731	A-286 CRES AMS 5731 or 300 SERIES CRES PER ASTM-A-493	CHEM. FILM MIL-C-5541 plain color	PASSIVATE QQ-P-35	NONE	NONE

GRIP DASH NO.	GRIP LIMITS		-4 DIA		-5 DIA		-6 DIA	
	MIN	MAX	L ±.015	K REF	L ±.015	K REF	L ±.015	K REF
-01	⑤	.062	.150	.35	.157	.38	.160	.42
-02	.063	.125	.213	.48	.220	.51	.235	.55
-03	.126	.187	.275	.53	.282	.55	.297	.59
-04	.188	.250	.338	.59	.345	.61	.360	.65
-05	.251	.312	.400	.65	.407	.67	.422	.71
-06	.313	.375	.463	.72	.470	.74	.485	.78
-07	.376	.437	.525	.78	.532	.80	.547	.84
-08	.438	.500	.588	.84	.595	.86	.610	.90
-09	.501	.562	.650	.90	.657	.92	.672	.96
-10	.563	.625	-	-	-	-	.735	1.03

NOTES:

- ① Head markings and lock collar visible after installation. Head markings depressed .010 max. orientation optional.
- ② Minimum blind side clearance for satisfactory installation.
- ③ Material designation refers to chemical composition only.
- ④ Expander may be 1 or 2 piece design.
- ⑤ Minimum grip for -4 dia. is .025, for -5 dia. is .031, and for -6 dia. is .037.

CR6222 SST™ RIVET - 100° NOMINAL DIAMETER

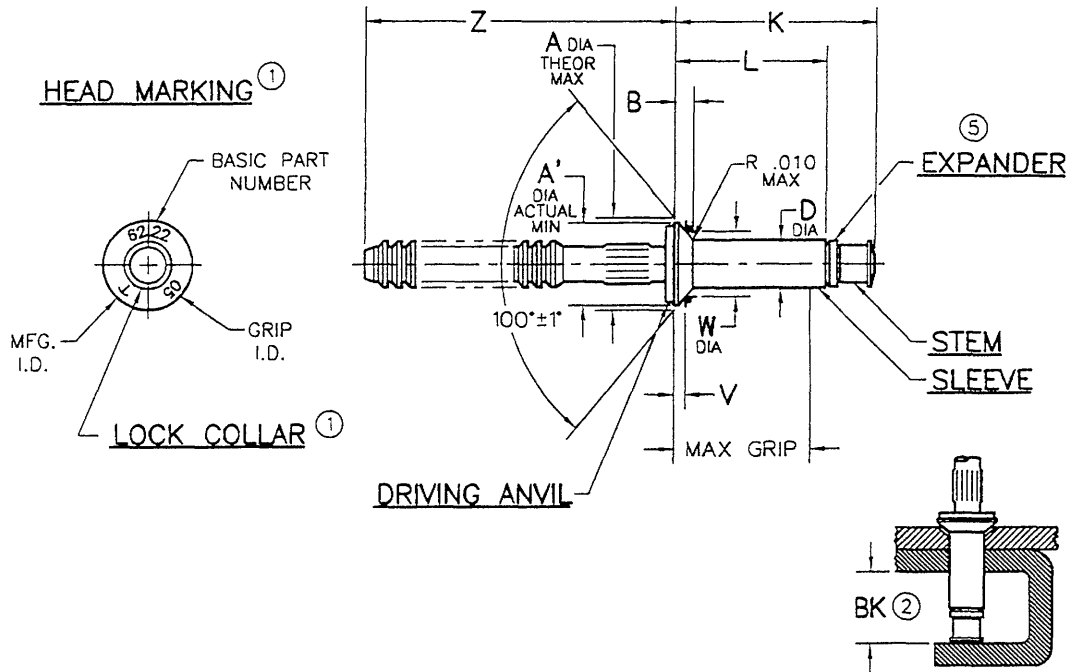

DIA. DASH NO.	A ^④ THEOR MAX	A' ACTUAL MIN	B ^④ MAX	D ±.002	Z REF	BK ^② MIN	V ±.0015	W ±.0001	RECOMMENDED HOLE LIMITS
-4	.229	.207	.044	.127	.87	.355	.0170	.1840	.129/.132
-5	.290	.268	.057	.158	.94	.370	.0215	.2340	.160/.164
-6	.357	.335	.072	.190	.94	.415	.0285	.2840	.192/.196

MATERIAL ^③				FINISH			
SLEEVE	STEM	LOCK COLLAR	EXPANDER	SLEEVE	STEM	LOCK COLLAR	EXPANDER
5056 ALUM. QQ-A-430	A-286 CRES AMS 5731	A-286 CRES AMS 5731	A-286 CRES AMS 5731 or 300 SERIES CRES PER ASTM-A-493	CHEM. FILM MIL-C-5541 plain color	PASSIVATE QQ-P-35	NONE	NONE

GRIP DASH NO.	GRIP LIMITS		-4 DIA		-5 DIA		-6 DIA	
	MIN	MAX	L ±.015	K REF	L ±.015	K REF	L ±.015	K REF
-02	⑥	.125	.213	.42	.220	.44	.235	.46
-03	.126	.187	.275	.54	.282	.56	.297	.58
-04	.188	.250	.338	.58	.345	.60	.360	.64
-05	.251	.312	.400	.64	.407	.66	.422	.70
-06	.313	.375	.463	.71	.470	.73	.485	.77
-07	.376	.437	.525	.77	.532	.79	.547	.83
-08	.438	.500	.588	.83	.595	.85	.610	.89
-09	.501	.562	.650	.89	.657	.91	.672	.95
-10	.563	.625	-	-	-	-	.735	1.02

NOTES:

- ① Head markings and lock collar visible after installation. Head markings depressed .010 max., orientation optional.
- ② Minimum blind side clearance for satisfactory installation.
- ③ Material designation refers to chemical composition only.
- ④ Theoretical diameter "A" max. and head height "B" max. are for engineering reference only.
- ⑤ Expander may be 1 or 2 piece design.
- ⑥ Minimum grip for -4 diameter is .063, -5 diameter is .065, and -6 diameter is .080.

CR6224 SST™ RIVET - 100° NAS1097 FLUSH HEAD/NOMINAL DIAMETER

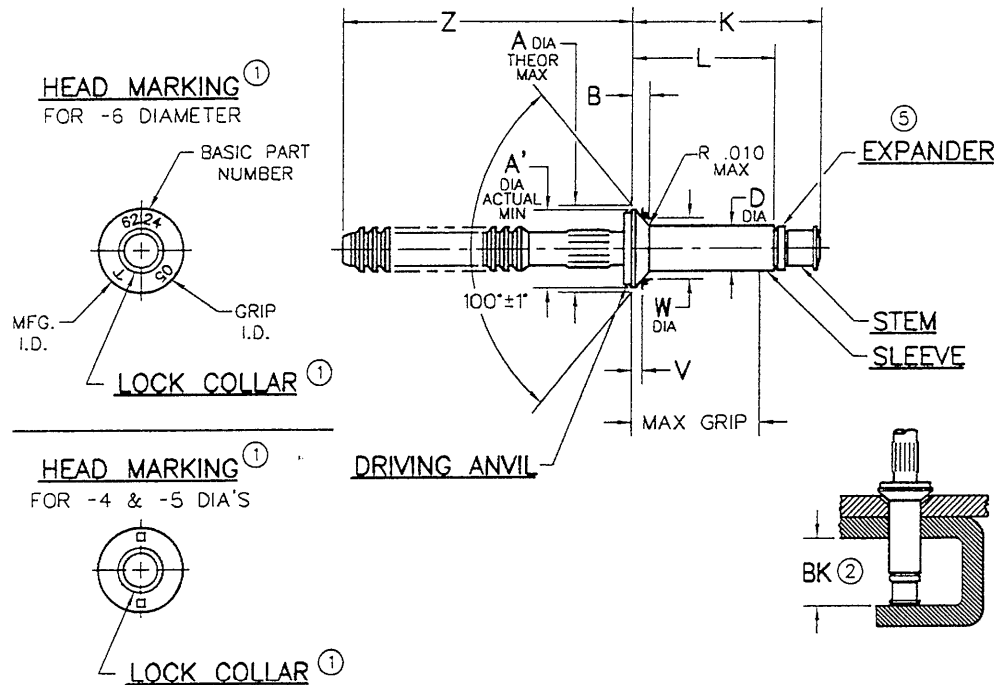

DIA. DASH NO.	A ^④ THEOR MAX	A' ACTUAL MIN	B ^④ MAX	D ±.002	Z REF	BK ^② MIN	V ±.0015	W ±.0001	RECOMMENDED HOLE LIMITS
-4	.197	.175	.030	.127	.87	.355	.0125	.1627	.129/.132
-5	.248	.226	.038	.158	.94	.370	.0170	.2027	.160/.164
-6	.304	.283	.048	.190	.94	.415	.0230	.2440	.192/.196

MATERIAL ^③				FINISH			
SLEEVE	STEM	LOCK COLLAR	EXPANDER	SLEEVE	STEM	LOCK COLLAR	EXPANDER
5056 ALUM. QQ-A-430	A-286 CRES AMS 5731	A-286 CRES AMS 5731	A-286 CRES AMS 5731 300 SERIES CRES PER ASTM-A-493	CHEM. FILM MIL-C-5541 plain color	PASSIVATE QQ-P-35	NONE	NONE

GRIP	GRIP LIMITS		-4 DIA		-5 DIA		-6 DIA	
	MIN	MAX	L ±.015	K REF	L ±.015	K REF	L ±.015	K REF
-02	⑥	.125	.213	.42	.220	.44	.235	.46
-03	.126	.187	.275	.54	.282	.56	.297	.58
-04	.188	.250	.338	.58	.345	.60	.360	.64
-05	.251	.312	.400	.64	.407	.66	.422	.70
-06	.313	.375	.463	.71	.470	.73	.485	.77
-07	.376	.437	.525	.77	.532	.79	.547	.83
-08	.438	.500	.588	.83	.595	.85	.610	.89
-09	.501	.562	.650	.89	.657	.91	.672	.95
-10	.563	.625					.735	1.02

NOTES:

- ① Head markings and lock collar visible after installation. Head markings depressed .010 max., orientation optional.
- ② Minimum blind side clearance for satisfactory installation.
- ③ Material designation refers to chemical composition only.
- ④ Theoretical diameter "A" max. and head height "B" max. are for engineering reference only.
- ⑤ Expander may be 1 or 2 piece design.
- ⑥ Minimum grip for -4 diameter is .063, -5 diameter is .065, and -6 diameter is .080.

SST™ TOOL SELECTION

THE TOOLING AND PULLING HEAD COMBINATIONS SHOWN IN THE CHART BELOW WILL INSTALL OVERSIZE AND NOMINAL DIAMETER RIVETS INDICATED BY THE SHADED AREAS, IN ALL GRIP LENGTHS AND HEAD STYLES.

CHERRY RIVETER MODEL	PULLING HEAD NUMBER	RIVET DIAMETER		
		-4	-5	-6
G27	-			
G686B-S	H680B200A			
G689	H680B200A			
G700	H680B200A			
G701A	H701B-456			
	H753A-456			
	H781-456			
G704B G704B-40SH G704B-SR	H701B-456			
	H753A-456			
	H781-456			
G744 G744-85SH	H846A-456			
	H846A-456			
G746	H701B-456			
	H753A-456			
	H781-456			
G749A	H749A-456			
	H753A-456			
	H781-456			
G750A	*			
G784	H680B200A			

* G750A supplied with straight head. Offset and right angle heads require adapter 750-050.

FOR MORE INFORMATION REGARDING TOOLING COMBINATIONS, PLEASE CONTACT TECHNICAL SERVICES, CHERRY TEXTRON, SANTA ANA, CA
(714) 850-6048

SST™ AND CHERRYMAX® RIVETERS

THE G704B PNEUMATIC RIVETER

NSN 5130-017-393-1584 Military Part Number M85188T2

The Cherry G704B is a pneumatic-hydraulic tool designed specifically for the most efficient installation of SST™ and CherryMAX® rivets. It weighs 4 1/4 lbs. and can be operated in any position with one hand. It has a .518" rivet setting stroke and a rated pull load of 3,136 pounds with 90 psi air pressure at the air inlet.

Pulling heads are not furnished with this riveter and must be ordered separately.

The straight H701B-456, right angle H753A-456, and the offset H781-456 pulling heads fit directly on the G704B riveter to install SST™ and CherryMAX® rivets. Extensions are available for extending the pulling heads and to reach limited access areas. See the CherryMAX® catalog for more information.

The G704B riveter, using the pulling heads listed, will install SST and CherryMAX® Bulb rivets in 1/8", and 5/32", and 3/16" nominal and oversize diameters in all head styles and materials.

Additionally, this riveter using the heads noted above will install **All-Aluminum CherryMAX® Bulb** rivets in 1/8" and 5/32" **oversize** diameters in all styles and grip lengths, and 1/8" and 5/32" diameter 'S' type Maxibolts.

This riveter will install short grip, serrated stem MS-type rivets using either the H9015 (with the 704A9 adapter) or H9040 (with the 704A6 adapter) pulling heads.



G750A HAND RIVETER

The Cherry hand hydraulic riveting tool provides the versatility of a pneumatic-hydraulic riveter, but with the lightweight, high pull strength ratio desirability not found in other hand riveters. The tool weighs just 1.9 lbs., has a .750" pulling stroke, and has a rated pull load of 3800 lbs. The Cherry G750A has a unique 2-step hydraulic power cylinder that provides the user with the ease of pulling the handle without the strain normally endured to install a high strength fastener. This patentable 2-step power feature allows the user to squeeze the handle throughout the increase power requirement, without feeling the need to squeeze harder to install the fastener.

The Cherry G750A hand riveter can install a variety of blind fastener styles, diameters, head configurations, and material combinations without changing the pulling head or adjusting the tool.

The G750A includes a straight pulling head. The H781-456 and H753A-456 heads require an adapter No. 750-050.

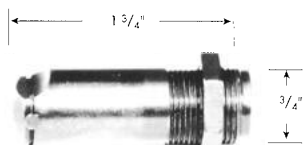

H701B-456 STRAIGHT

NSN 5130-01-393-2927
Military Part Number MB5188S1

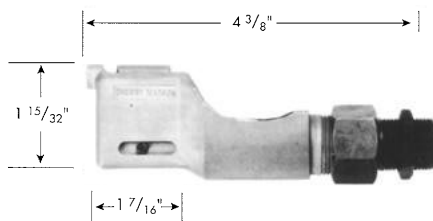

H781-456 OFFSET

NSN 5130-01-393-2925
Military Part Number M85188S3

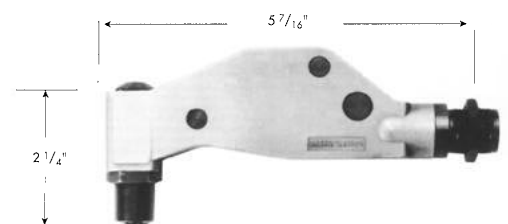

H753A-456 RIGHT ANGLE

NSN 5130-01-393-2926
Military Part Number M85188S2

THE VERSATILITY OF CHERRY TOOLING

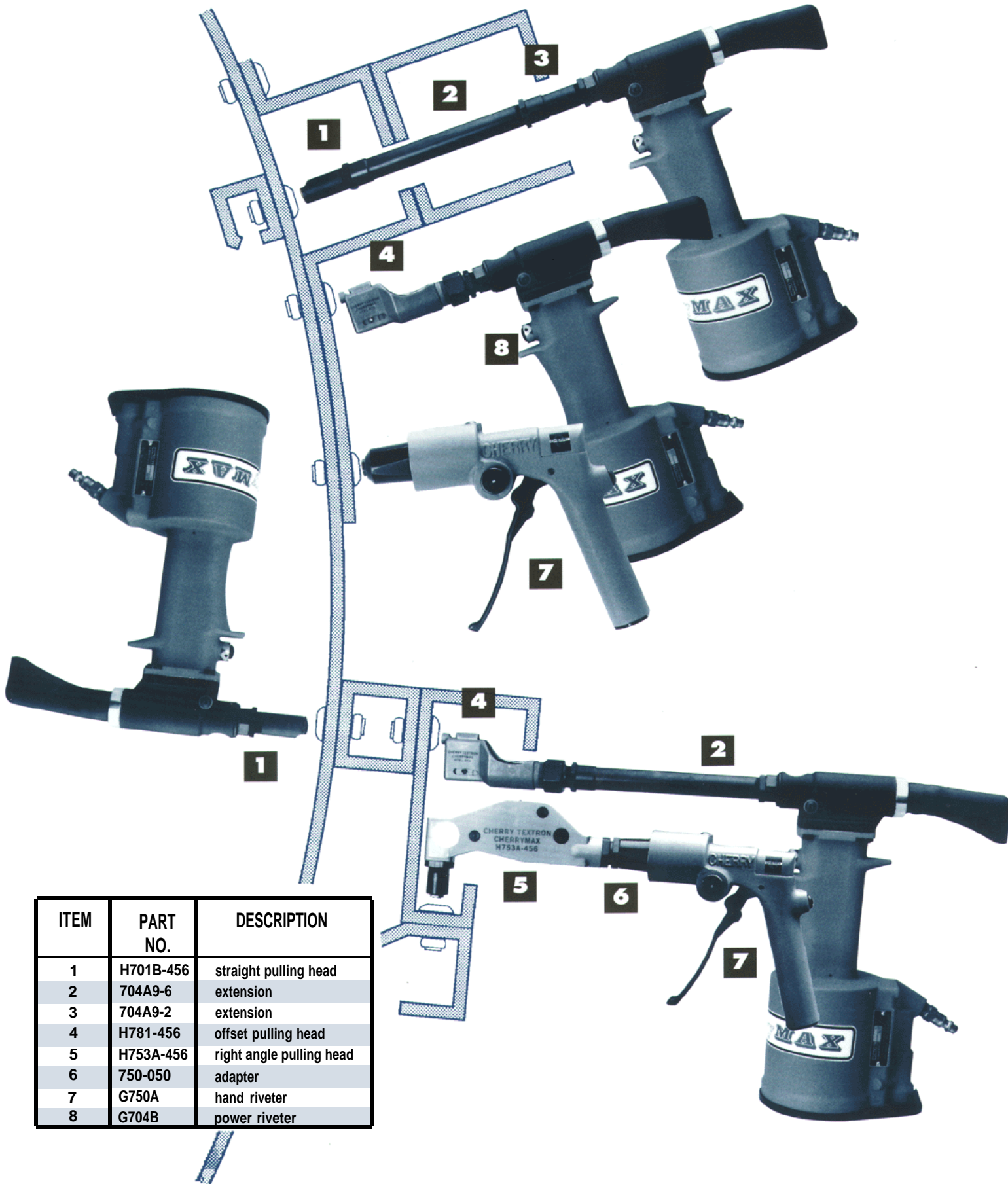

ITEM	PART NO.	DESCRIPTION
1	H701B-456	straight pulling head
2	704A9-6	extension
3	704A9-2	extension
4	H781-456	offset pulling head
5	H753A-456	right angle pulling head
6	750-050	adapter
7	G750A	hand riveter
8	G704B	power riveter

WARRANTY

Cherry, a Division of Textron Inc. (hereinafter 'Cherry') hereby warrants to the initial retail customer and original installer ('Warranty') only that its products will be free from defects in material and workmanship, provided that the products are used in accordance with Cherry's instruction as to maintenance, operation and use.

The warrantor's only remedy and Cherry's only obligation in the event of a defect or failure in the products, is that Cherry will, at its sole option, repair, replace, or rework the products, but in no case shall the cost of the foregoing exceed the invoice price of the products.

This Warranty shall be void if any person seeking to make a claim for defective or failed products fails to notify Cherry within thirty (30) days of receipt of evidence that the product is defective or has failed, or if said person fails to provide Cherry with such evidence as is reasonably requested concerning the defect or failure, including without limitation, evidence of the date of purchase and date of installation.

THIS WARRANTY IS IN LIEU OF ALL OTHER WARRANTIES EXPRESSED OR IMPLIED, INCLUDING MERCHANTABILITY OR FITNESS FOR A PARTICULAR PURPOSE TO THE EXTENT NOT EXPRESSLY PROVIDED FOR HEREIN, OR CONSEQUENTIAL DAMAGES ARISING FROM ANY DEFECT OR FAILURE IN ITS PRODUCTS.

NOTE: The properties, strengths, dimensions, installed characteristics and all other information in this catalog is for guidance only to aid in the correct selection of the products described herein and is not intended or implied as part of the above warranty. All applications should be evaluated for functional suitability and sample parts are available upon request for installed tests, suitability and evaluation.

Supplier's Federal Identification Code - 11815

CHERRY **TEXTRON**

Cherry Division of Textron, Inc.

We Have Something To Hold Your Interest.



Cherry and Avdel Textron provide a variety of products and services based on their complete in-house capabilities to research, develop, manufacture, and market fastener products. For over fifty years, Cherry and Avdel Fasteners have been the leaders in providing the aero-

space industry with MS, NAS and proprietary fastener systems.

With Cherry and Avdel's large product line and experience, we are sure to have just the right product to hold your interest.

OUR WIDE RANGE OF PRODUCTS INCLUDES

- CherryMAX® Blind Rivets
- CherryMAX 'A' Blind Rivets/NAS1398 & 99
- Cherry SST™ Blind Rivets
- CherryLOCK® Blind Rivets/NAS1398 & 99, NAS1738 & 39
- Cherry MS & Nut Plate Rivets
- Cherry Intermax Blind Rivets
- Cherry/Avdel Pneumatic-Hydraulic Rivet Installation Tools
- Avdel MBC®/NAS1719-1721
- Avdel Chobert®
- Cherry MaxiBolt Blind Bolts/MS90353 & 54, MS21140 & 41
- Cherry Titanium Maxibolt Blind Bolts
- Cherry Lockbolts & Collars
- CherryBUCK® Titanium Shear Pins
- Cherry E-Z BUCK® Titanium Shear Pins
- Cherry ACP All Composite Shear Fasteners
- Cherry/Avdel Hand Operated Rivet Installation Tools
- Avdel Jo-Bolt/Jo-Lok™
- Avdel Quick Release Pins per NAS1332

ALL CHERRY® AND AVDEL PRODUCTS ARE SUPPORTED BY A WORLD-WIDE AUTHORIZED DISTRIBUTION NETWORK.

CHERRY

Cherry Textron, Inc. 1224 East Warner Ave., PO. Box 2157, Santa Ana, CA 92707-0157
714-545-5511 FAX 714-850-6095

Avdel
TEXTRON